

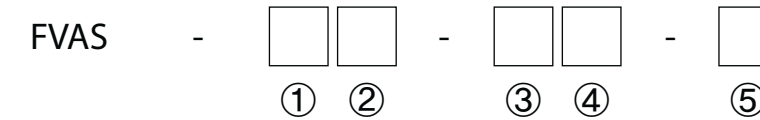

**Stainless Valve**  
Stainless body PTFE diaphragm valve

# FVAS

**ORDERING INFORMATION**



FVAS	① Body	② Actuator	③ Operating	④ Connection		⑤ Option
	S : SUS 316	E : PP(표준) P : PVC H : 고온용	C : Normal Close O : Normal Open D : Double Acting	3 : 3/8" 4: 1/2" , 15A 5 : 3/4" , 20A 6 : 25A 7 : 32A 8 : 40A 9 : 50A-(FVA9000)	P : FPT F : Flange	1 : No option 2 : Indicator 3 : Flow control 4 : By - Pass 5 : Flow Control + By Pass

**DIMENSION**

For exact size of each item, Please contact Sales Dept. Above-men tioned dimensions are changeable.

설계치수는 영업부에 문의 또는 승인도를 요청 바랍니다. 상기 치수는 변경될 수 있습니다.

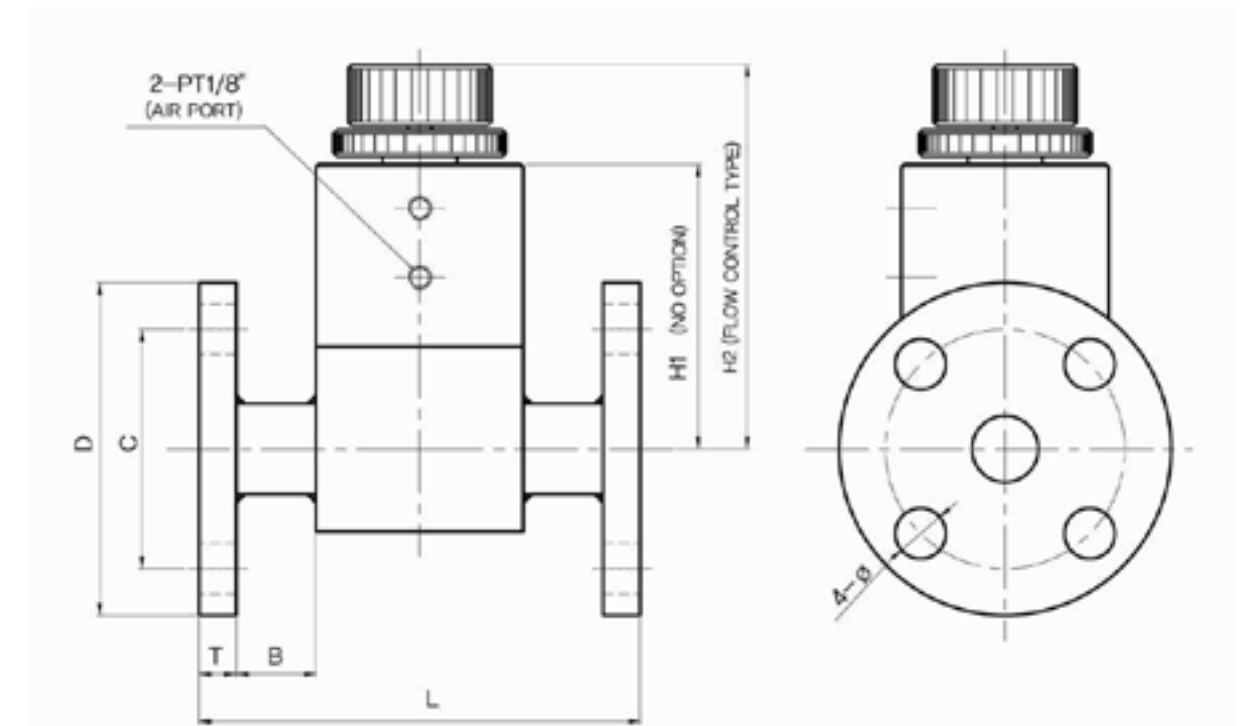

MODEL	CONNECTION	L	H1	H2	D	C	□	T	B
FV□-3040	15A	118	77.5	95	95	70	15	12	20
FV□-5060	20A	166	107	144.5	100	75	15	14	30
	25A				125	90	19		
FV□-7080	32A	190	144.2	181.5	135	100	19	16	29
	40A				140	105	19		

**Specification**

- OP.Temp : 5~50°C(60°C)
- OP.Press(ordinary) : 0~4kg/cm<sup>2</sup>
- OP.Press(reverse) : 0~2kg/cm<sup>2</sup>
- Air Press : 4~6kg/cm<sup>2</sup>
- Cycle : 10cycle/min

- 사용온도 : 5~50°C(60°C)
- 사용압력(정) : 0~4kg/cm<sup>2</sup>
- 사용압력(역) : 0~2kg/cm<sup>2</sup>
- 작동압력 : 4~6kg/cm<sup>2</sup>
- 작동회수 : 10회/min

**Applications**

- Equipment with organic solvent
- Solvent 등 유기용제 사용 장비

**General**

This is diaphragm valve with stainless steel body. Connection is 15A~50A flange type and mostly suitable for equipment with organic solvent.

15A~50A flange connection type의 stainless steel body의 diaphragm valve입니다. 주로 solvent 등에 유기용제를 사용하는 장비에 적합합니다.

**Features**

- SUS316 wetted parts
- PTFE diaphragm
- Smooth fluid flow & less pressure loss due to big orifice
- 15A~40A Flange connection
- NC, NO, Double Acting by air
- Indicator for movement's confirmation, flow control function
- Ultrasonic washing by DI water & vacuum packing

- SUS316 접액부
- PTFE diaphragm
- 큰 orifice 구조로 원활한 유체유동과 적은 압력손실
- 15A~40A Flange connection
- Air 구동의 NC, NO, Double Acting
- 동작 확인용 indicator, 유량 조절 기능 부착
- Degreasing, DI water로 초음파 세정 및 진공포장